

# MTVF2.4X0915IR-BCD

Type	AI VARI		Mount	ø14 Straight Mount		
Focal Length	9.0~22.0mm		Back Focus	6.7~14.2mm		
Fno.	F1.5		Flange Back	13.8mm		
Designed Image Format	1/3"(4.8x3.6mm)		Exit Pupil	-40.8 ~ -25.6mm		
Operation Range	Iris	F1.5-F360	Filter Size	-		
	Focus	0.50m~∞	Aperture	Front ø8.2mm		
	Zoom	9.0~22.0mm		Rear ø7.1mm		
Control	Iris	DC Galvanometer	Dimension	ø29.2 x 40.2mm		
	Focus	Manual			Weight	22g
	Zoom	Manual				
Object Size at MOD	Wide	207.6x284.8mm				
	Tele	88.4x118.2mm				
Field of View	D	39.0°~16.2°	1/4"	28.6°~12.2°		
	H	30.6°~13.0°	1/3"	22.6°~9.8°		
	V	22.6°~9.8°		16.8°~7.2°		
Control	Iris		Focus	Zoom		
Driving Coil/Supply Volt.	190Ω		-	-		
Damping Coil/Current	465Ω		-	-		
Response Time	-		-	-		
Potentiometer	-		-	-		
Light Measuring Method	-					
Input Signal	-					
Iris Accuracy	-					
Sensitivity Adjustment	-					
Operating Temperature	-10 ~ +50 degree C					

1/3"

FM

BCD

## DIMENSIONS

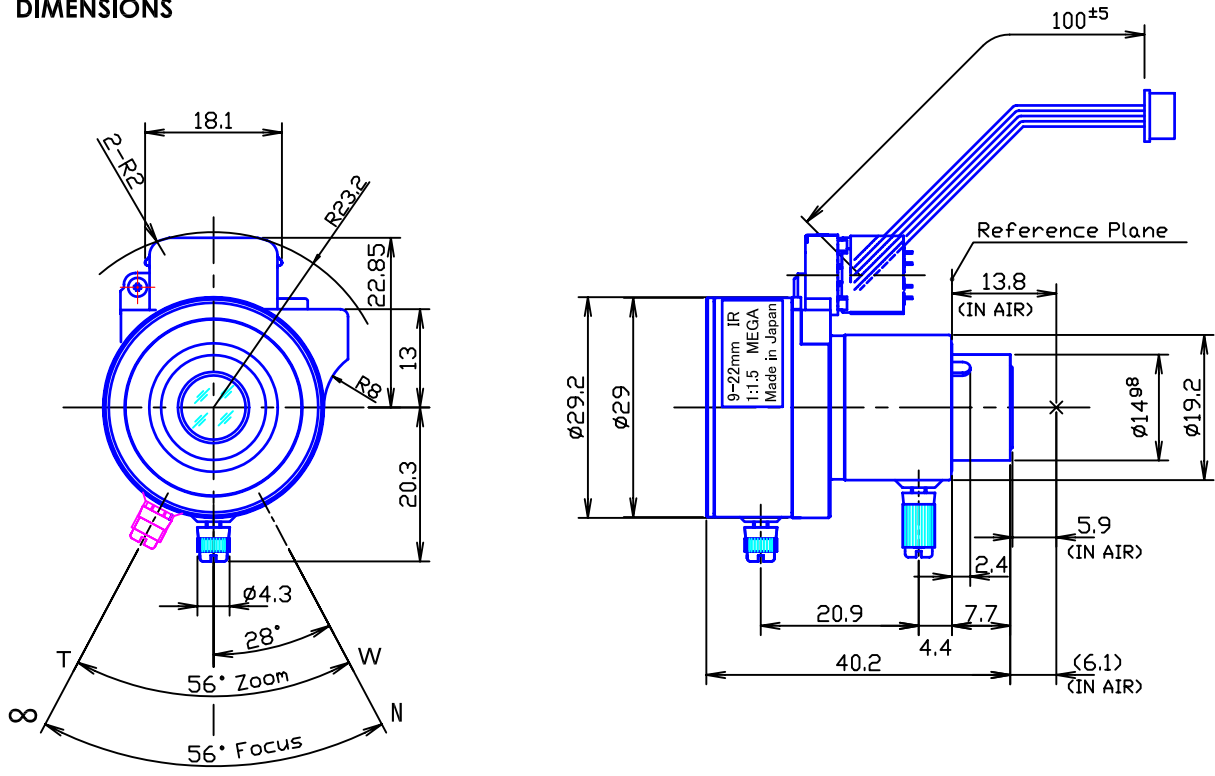

## Wiring Diagram

1) 4-pin Connector for Auto Iris  
(Molex : 51021-0400 Single Socket)

Pin No.1	Yellow	Damping(+)
2	Orange	Damping(-)
3	Brown	Driving (+)
4	Red	Driving (-)